

SPECIAL CRANE SCALE MAKER

DIRECTION BOOK OF

MODEL: SC

PORTABLE

HIGH ACCURACY DIGITAL DISPLAY

ELECTRONIC CRANE SCALE

OVERALL PAST THROUGH THE ISO9001

INTERNATIONAL QUALITY SYSTEM CERTIFICATION

Catalogue

1.Special features and functions

2.Primary technical characters and parameters

3.Basic operation

4.Guide of special display symbol

5.Simple troubles and solutions

6.Diminsions and weights

7.Maintence

8.The parameters of the machine and calibration
method

In order to correctly use your scale and keep it in good condition, please do read the direction book carefully and place it on hand for reference

Catalogue

1. Special features and functions
2. Primary technical characters and parameters
3. Basic operation
4. Guide of special display symbol
5. Simple troubles and solutions
6. Dimensions and weight
7. Maintenance.
8. The parameters of the machine and calibration method

1. Special features and functions

(1). Features

SC digital electronic crane scale is high accuracy, one-side direct display measuring unit which combines scale, load cell and power supply together. It can be directly hung on the hook of a hoist and ensure the scale to complete the tasks of loading and weighing goods synchronously. The screen is made up of super-bright digital tube (LED) or liquid-crystal display (LCD), which can be easily seen in 25 meters. The scale body is made of strong alloy aluminum. Its structure is compact and operation is quite easy.

This type of scale can be widely used in manufacturing, fabric producing, chemical and medicine engineering, Keeping grain and goods in the storehouse, buying and selling of farming product etc. It is really a satisfying scale for modern management and high production efficiency.

This type of scale can meet following standards.

- ① JJG539-97 《Verification regulation of digital display scale》
 - ② JJG555-96 《general verification regulation of non-automatic scale》
 - ③ International organization for legal metrology(OIML)
- International suggestion R76 of non-automatic weighing instrument, etc.

(2). Exceptional functions

- ① Software calibrating convenient, rapid, trustworthy, cheat-preventing.
- ② Voltage measuring monitoring the battery voltage in scale conveniently
- ③ Auto power off turning off automatically after 1.5 hours no-working prevent battery from damaging by operator's negligence.
- ④ Taring automatically ensuring the scale to work normally in any special environment.
- ⑤ Accumulative saving The scale can gradually save the random weight over 200 times by the use of the remote controller. It will not loss the data after Turn ng off the power, and can review conveniently. (only the customer who has the remote controller can apply this function).

2. Primary technical parameters and characters

(1). Basic parameters

MODEL	MAXIMUM CAPACITY	MINMUM CAPACITY	DIVISION	NUMBER OF DIVISION
SC-06	660.8 lbs	4.4 lbs	0.22 lbs	3000
SC-2	2202.6 lbs	22.0 lbs	0.55 lbs	2000
SC-4	4405.3 lbs	44.1 lbs	2.2 lbs	2000
SC-6	6607.9 lbs	44.1 lbs	2.2 lbs	3000

(2). Main technical characters

Accuracy	OIML III
Taring range	100% FS
Result steady display	3~7 Seconds
Alarm of over weight	110% FS
Max safe load	125% FS
Limit coefficient	4
Power supply	Full seal airtight recharge battery 6v/10AH
Display tube	Super-bright LED or LCD(height 30mm/5 bit)
Working temperature range	-10°C~+40°C
Working humidity range	20°C<90%RH

3. Basic operation

(1). Starting

Turn on the power switch on the side panel of the scale. The screen will show "88888". When the buzzer sounds one time, the screen shows the battery voltage "u**.**" about 5 seconds, then the circuit is checked automatically and the screen will display "99999", "88888", "00000" in turn. At last it will display "0"kg, now It's ready for measuring.(after the scale is turned on, It usually needs electric preheating about 3-5 minutes.)

(2). Taring

When the scale is turned on, the screen will show "0"kg. If it doesn't show "0" please press "taring"key.

(3). Measuring.

Hang the object from the ground till it is motionless in the air. Then the screen will show the object's

weight. If there is any steel rope accessory on the object. Before the measuring, the steel rope accessory must be hung on the scale hook, then press the "taring" key please. The screen shows "0"kg. After that hang the object again, now the screen will show net weight of the object. As microchip in the scale can store the value of accessory weight, every time you can get the net weight of the object till you change the accessory weight or turn off the scale.

(4). Battery checking

Start the scale, the screen will show "88888", the buzzer sounds one time, then the screen shows the battery voltage "u**.**" automatically (above 6.00v normally), you can check it and turn off the scale.

(5). Turning off

After using, turn off the power switch on the side panel of the scale, in prevent of damaging to battery. If voltage is lower than 5.5v recharge it in time.

(6). Recharging

Turn off the switch on the side panel of the scale the screen will be put out. Insert charger's plug into the socket of "220v~". Then connect the charger and the scale with a lead. The indicating lamp on the rear side of the panel will be on. The scale now is in the course of recharging.

(7). The application of the wireless remote controller(only the customer who has bought the remote controller can use this function).

①. Taring key <A>:

If there is no weight on the scale, the scale screen doesn't show "0"kg, or it's needed to tare, press the key <A> please.

If you press the key <A> 2 times in one second, the screen show "dLP", now the scale is in the state of automatic taring, and after 20 seconds, the scale will be steady and begin to tare.

②. Display keeping key :

If the weight display of the screen needs to be held, Press the key please. now the weight display is locked and flashed. When it does not need to be held, press the again. The screen shows normally.

③. Weight accumulative saving key <C>:

When the random weight needs to be accumulated, press the key <C> please. The scale screen will show "NO.**", there "***" is accumulative times. At the same time, The random weight will be saved automatically and it can be reviewed conveniently.

Note: the accumulative saving function can't be applied to zero and minus.

④. Function conversion key <D>:

If other functions need to be executed, please press the key <D>, the scale screen will show "Func", then press the request key.

◆ Key <A>: accumulative value and weight clear

Before the object weight is to be accumulated, the clear zero operation must be executed, in order to prevent into error.

When press the key <A>, the scale shows "clr0", then you will be asked to confirm whether the clear zero operation must be executed.

"Yes", press the key <A> again. The scale shows "clr1", the accumulative value and weight will be cleared and after a few seconds the scale will return to weighing state automatically. "No", press key <D> please and it returns to weighing state

◆ Key : checking the battery voltage

Press the key , the scale shows "U**.**" then press key <D>, It returns to weighting state.

◆ Key <C>: inquiry about accumulative value and weight

Press the key <C>. The scale shows accumulative times "No.**". After a few seconds, it shows the high four bits of the accumulative value "H****", and soon shows the low four bits "L****" again. If press key <D>, it will return to weighting state. When you want to inquire about every weight, please press the key <C>, the scale screen shows weighting order "No.01", press the key <C> again, shows the weight "*****". Press the key <C> continuously, the scale shows the order "No.02" and press again, it shows the weight too. When the scale shows "END", all of the weighting records will be completed to inquire and it will automatically return to weighting state. If you want to stop the inquiring state and return to the weighting state, please press the key <D>.

◆ Key <D>: press the <D>, return to the weighting state immediately.

Note: the key with mark ◆ is group function key. Only pressed the key <D>, as the scale screen has showed "FUNC", press the correspondent group function key again, its function can be carried out.

(8) For the portable scale ocs-5t-xzL and ocs-10t-xzL there are four buttons under the display block. The functions of the four buttons from Left to right are in accord with A, B, C, D of wireless remote controller. We can operate these buttons manually to carry out the function of the wireless remote controller.

4. Guide of special display symbol

(1). Overweight symbol "OE"

If the weight on the scale exceeds the alarm lever, the screen will show "OE" and overweight gross value "XXXXX" alternately

(2). Automatic taring prompt "dLP"

In the course of taring, when you press the "Taring key" <A>, it will show "0" kg after a second in normal condition. But if you press the "taring key" twice in a second, the scale will show "dLP" and will be in the condition of automatic time-delay measuring the net weight. After 20 seconds the taring weight hung on the scale will be in steady state. It can tare the gross weight automatically, the screen shows "0". This function is specially suitable for extremely heavy object which is unable to press "taring key" when measuring.

(3). Prompt of reverse force to load cell "Ad-"

When a scale is put on the ground, the load cell undertakes the reverse force, sometimes the screen will show the prompt "Ad-", but it will disappear when the scale is hung in the air, it is a normal phenomenon unless the load cell leads are damaged or broken.

(4). Low battery voltage "ULbL"

When the battery voltage in the scale is lower than 5.5v, the screen will show "ULbL", it suggests low battery voltage in the scale, please recharge it in time.

(5). Waiting prompt "—"

When the scale is set at "automatic turn off", it needs to be static about 5 minutes, the screen will show "—". Now the scale is at "save electricity" and it returns to normal display immediately till the weight changed.

5. Simple troubles and solutions

Phenomeana	Judgement	Solutions
No display after starting	Battery needs to be recharged	Turning off the scale and recharging
	Broken battery	Replacing battery (at normal state, above 6v)
Battery can't be charged	Broken charger	Replacing charger(it can supply above 10v normally)
	Broken battery	Replacing battery
Indicating lamp for recharging is not working	Charger not in good contact	Re-plugging and keeping in good contact.
	No power(220v~)in socket	Checking socket
Unsteady dispay value	Battery voltage too low	Turning off the scale and recharging
	Motion of weighting object	Let weighting object be static
Display of empty scale is not equal to "0"	Preheating time too short	Preheat the scale for 3~5 minutes, then press taring key
	Putting scale on ground for excessive time	Improving the style of storage and scale should be hung freely

6. Dimensions and weight(for reference)

MODEL	SIZE (inch)				(N.W) (lbs)
	E	F	G	H	
SC-06	1-3/4	2-3/8	13/16	14-3/16	22
SC-2	2-3/16	2-9/16	1-3/8	16-1/2	26.4
SC-4	2-3/16	2-9/16	1-3/8	16-1/2	26.4
SC-6	2-3/16	2-9/16	1-3/8	16-1/2	26.4

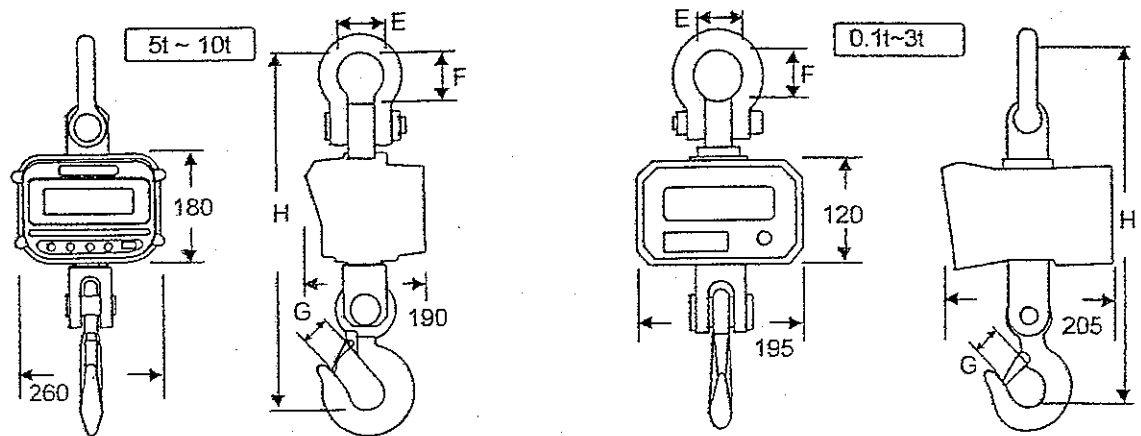

7. Maintenance

Electronic crane scale is a exquisite measuring unit. Its power comes from storage battery. Daily maintenance must be needed:

- When the scale is turned on, it usually need to be preheated for 3~5 minutes, then begins to weight.
- It should be avoided to be overweight in a long term, otherwise the load cell will be damaged forever.
- Recharge the battery after every using. If it is not used in a long time, please recharge it once a month.
- If the scale is not needed, hang it or put it on a small vehicle. Do not let the hook touch any object. The storage environment should be dry and clear.
- Should often check the scale's bolt, screw and ensure them in a good condition.
- The storage battery of the scale does not belong to the range of exchange, repair and return. The user must usually recharge and maintain it. It can be used by day and recharged by night. In this way the battery's use life can be delayed.

8. The parameters of the machine and calibration method

(1). The parameter table

- P00 password(the value set by the factory is 34)
- P01 grade choice:1. 2. 5. 10. 20. 50 (grade III scale, set by the factory)
- P02 display unit: 0: kg 1:Tb(0.set by the factory)
- P03 amplitude range: 1. 2. 3. 4. 5. 6. 7. 8. 9. (5,set by the factory)
- P04 patten for turning off the scale:
 - 0: manual,
 - 1: at waiting state after 5 minutes,
 - 2: time-delay automatic turning off (1.5hr.)
 - (2.set by the factory)
- P05 position of decimal point:0. 1. 2. 3.
- P06 calibration point:
 - 0:no(automatically follow the track of zero),
 - 1:one point,

2:two points

3:three points(0,set by the factory)

- P07 rated weight.
- P08 alarm lever: 110% rated weight.
- P09 calibration weight M1: the first calibration weight M1.
- P10 calibration weight M2: the second calibration weight M2(M2>M1)
- P11 calibration weight M3: the third calibration weight M3(M3>M2).
- P12 calibration coefficient1: set by the factory.
- P13 calibration coefficient2: set by the factory.
- P14 calibration coefficient3: set by the factory.
- P15 turn point1: set by the factory.
- P16 turn point2: set by the factory.
- P17 tare weight: set by the factory.

(2). Definition of the key function

[A] taring; withdraw from the state of parameter setting.

[B] the parameter code, digital code progressively increases;[B]+[D],enter the status of the parameter setting.

[C] the flashing bit of the parameter cods (modifiable) shifts; display the parameter code and decrease progressively.

[D] confirm and convert the parameter, [B]+[D]enter the state of the parameter setting.

(3). Modification of the graduated value

press the key [B],[D]simultaneously, it will show" P00" ;

press the key[D],shows "34" ,press[D]again. Shows "P01" ;

then if you press[D], it will show the present graduated value" **" ,now press[B], select the display graduated value which you need. Please press[D], press[A]again, it will return to weight state and the scale will show the weight by the new graduated value.

The Appendix Manual for Calibration

1. Connection mode:

1.1 Adapting portable wireless remote controller:

The corresponding relationships described below are listed as follow:

A= **[Y]** ,B= **[-]** ,C= **[+]** ,D= **[X]** .

1.2 Adapting wired controller:

The copperplate "Cap.xxxxkg" should be firstly demounted from the display, and then to put a plug of fifteen cores into the calibrating socket and to operate as follow. When above actions are finished, the copperplate should be recovered to its original status.

2. Set of parameters:

To press buttons of both **[-]** and **[x]** at the same time ,there is an indication "POO" on the display. After that the crane scale is in the status of calibration and parameter set .In the case ,the value and functional numbers will be correspondingly increased by pressing the button **[-]** .To press the button **[+]** for the choice of displaying bit ,and decreasing the functional numbers when they are displaying function numbers .To affirm by pressing the button **[X]** .

Functional numbers, uses and values are shown as follows:

P00	Password: 34
P01	Rates: 1,2,5,10,20,50
P02	Shown value: 0:kg; 1:lb
P03	Range of vibration: 1,2,3,4,5,6,7,8,9

Following functional numbers can be used in the case of pressing buttons **[+]** and **[X]** at the same time:

P04	Switching off mode: 0: manually; 1:stand-by; 2: time delay automatic switching off.
P05	Decimal digit: 0, 1, 2, and 3
P06	Calibrating point numbers: 0: It cannot be calibrated; 1: one point; 2: two points; 3: three points.
P07	Setup rated weight
P08	Setup alarm value: 110% of rated weight.
P09	Calibrating weight M1: the first point for calibrating weight value
P10	Calibrating weight M2: the second point for calibrating weight value (M2>M1)
P11	Calibrating weight M3: the third point for calibrating weight value (M3>M2)

To stop setting parameters, pressing the button **[Y]** and system will return to weighing status.

3. Calibration (Parameters must be setting before calibrating)

Firstly, to press the button **[Y]** to get rid of tare.

The first point calibration : to hoist a calibrating weight that is previously set, then to press the button **[X]** after it is in stable status, and it displays "Func." To press both buttons of **[Y]** and **[-]** at the same time, it shows "bd1". Then it automatically returns to the weighing status several seconds later. Thus, the calibrating weight value is on the display.

The second point calibration : to hoist a calibrating weight that is previously set, then to press the button **[X]** ,and it shows "Func." To press both buttons of **[Y]** and **[+]** at the same time, it displays "bd2". Then it automatically returns to the weighing status several seconds later. The calibrating weight value is on the display.

The third point calibration: to hoist a calibrating weight that is previously set, after it is in stable status, then to press the button **[X]** ,and it displays "Func." To press both buttons of **[Y]** and **[X]** at the same time, it shows "bd3". Then it automatically returns to the weighing status several seconds later. The calibrating weight value is on the display.

The above processes can be repeated if there is a discrepancy between a shown value and a calibrating weight.